



Brandon

Modular Motion Group

1206 Brandon leather group
1506 Brandon fabric group

Photo above shown in 182-80 leather.

The automotive-inspired seat design is Brandon's signature style. Pillow pads rest on sweeping track arms. The double pillow back and chaise seating offer sink-in comfort. Multiple seating options are available in two leather colors and one fabric color.

Creating fine upholstered furniture for more than a century, Flexsteel offers comfort and durability, backed by a lifetime warranted blue steel seat spring. Warranties include the reclining mechanism for five years; seat cushions and frame for two years.



Shown in 425-54 leather.



Shown in 183-72 fabric.

LATTITUDES
collection by Flexsteel

Brandon

1206 group available in 182-80 and 425-54 leather.
 1506 group available in 183-72 fabric.



1206 / 1506-62



1206 / 1506-604



1206 / 1506-60



1206 / 1506-54



1206 / 1506-23



1206 / 1506-604 / -23 / -62
 Overall combined group dimensions as shown 38" h x 133" w x

Dimensions

- 62 Double Reclining Sofa
38" h x 83" w x 41" d
- 604 Gliding Reclining Love Seat with Console
38" h x 75" w x 42" d
- 60 Double Reclining Love Seat
38" h x 60" w x 41" d
- 23 Floating Full Wedge
38" h x 70" w x 44" d
- 54 Glider Recliner
38" h x 39" w x 41" d

1206 / 1506 Group Configurations

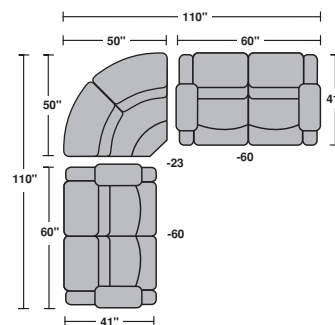
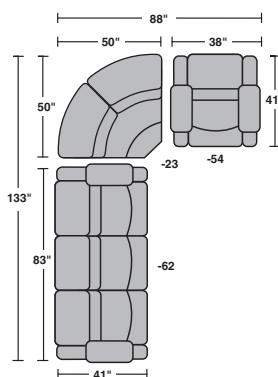
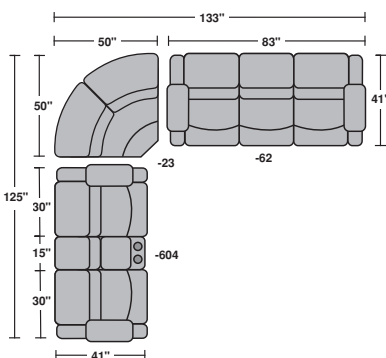

Frame:
Two-Year Warranty

Blue Steel Seat Spring:
Lifetime Warranted

Seat Cushions:
Two-Year Warranty

Reclining Mechanism:
Five-Year Warranty

